

BB  
104

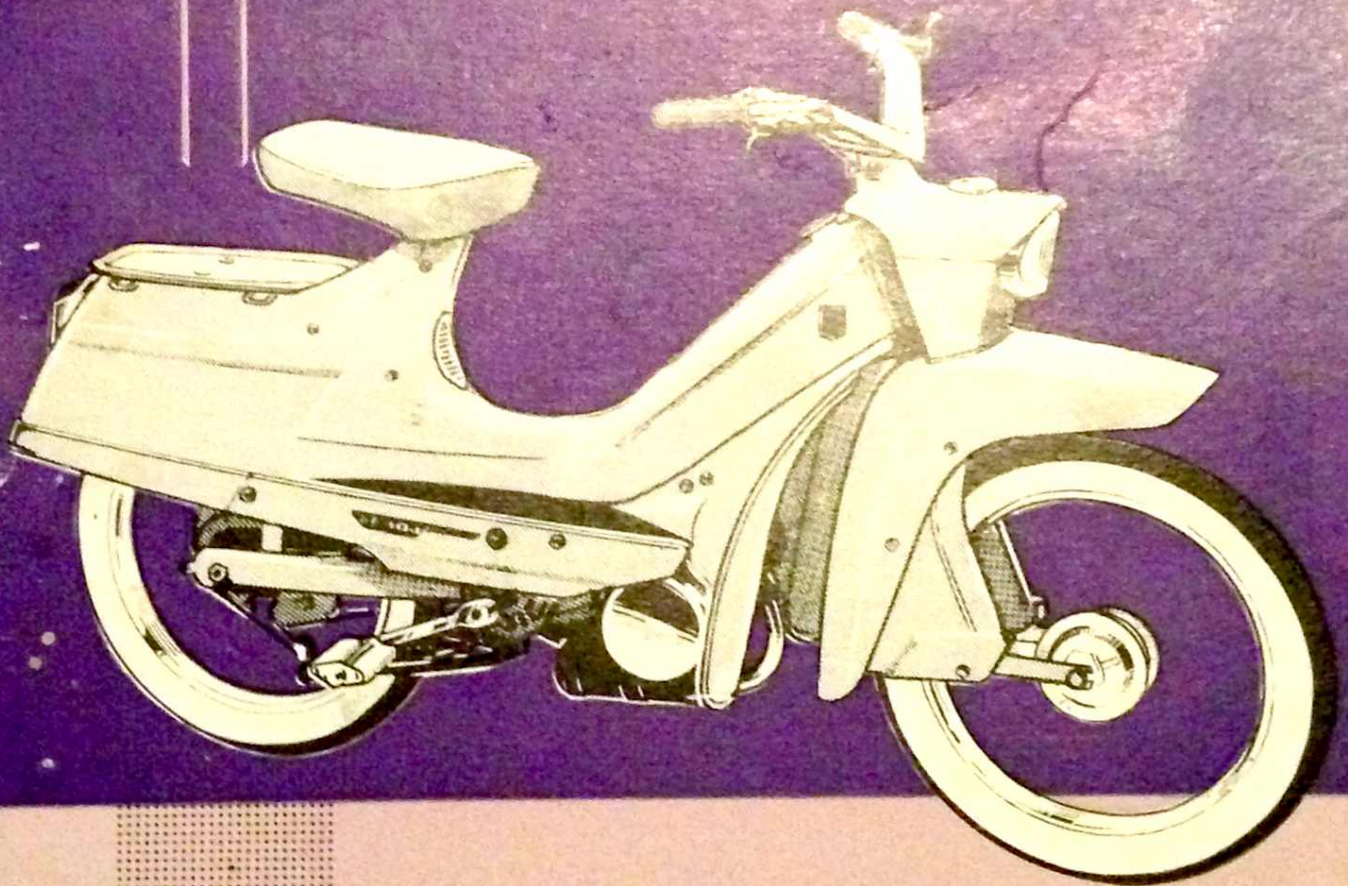

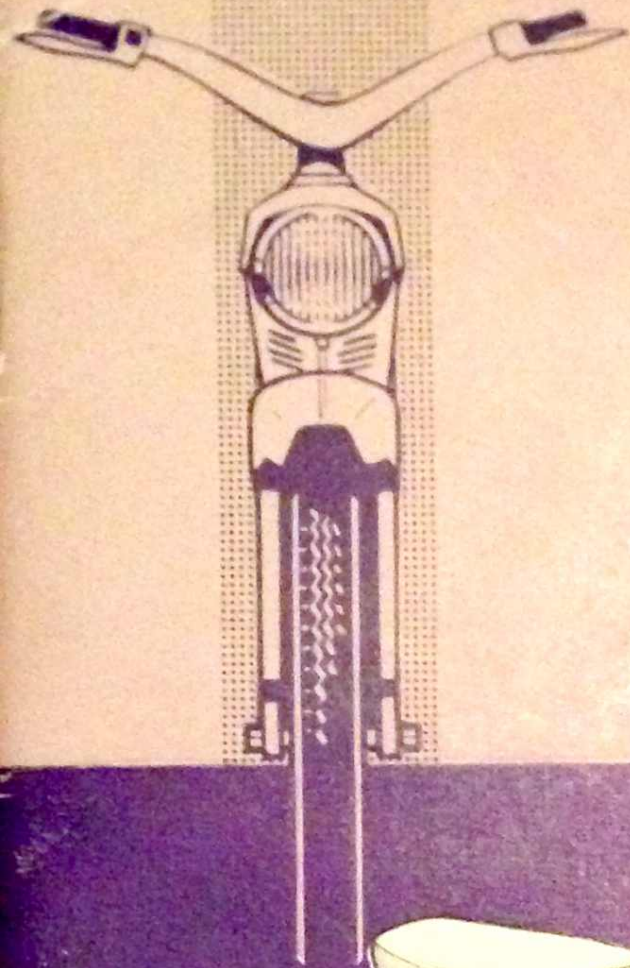

# Contents

	Pages
Adjustment of slow running .....	11
Adjustment of belt tension .....	14
Adjustment of chain tension .....	13
Carburettor .....	10
Automatic multi-plate clutch .....	16-17
Decarbonisation .....	18
Disconnection of the motor .....	13
Dismantling carburettor .....	11
Dismantling front fork .....	15
Dismantling silencer .....	14
Engine .....	20-21
Flywheel magneto .....	6-7-8
Headlamp .....	15
Instructions before starting off .....	3
Lubrication .....	9
Removal of rear wheel .....	12
Running in.....	3
Simple fault finding .....	22-23
Slowing and stopping .....	5
Starting off .....	4-5
Technical data .....	2



# *Technical data*

## **2 STROKE MOTOR WITH CRANKCASE COMPRESSION**

Bore 40 mm stroke 39 mm

Capacity 49 cm

Compression ratio 7.4 to 1

Ignition by Flywheel magneto

Ignition advance 3 mm

Primary drive by V - belt

Final drive by chain

Consumption : 150 m.p.g.

Fuel tank capacity 1 1/4 gallons

Weight approx. 100 lbs

Tyres front and rear 2 1/4 × 15

## *lighting*

Headlight 6 volts, 1 Amp

Rear Light 12 volts, 0.5 Amp



# Instructions before starting off

## FUEL

Put a previously prepared mixture of petrol and 6 % of good quality fluid oil in the tank.

While running in (about 600 miles : 1,000 km) the mixture should contain 8 % of oil.

Never use pure petrol as the engine would not be lubricated and would be put out of action.

## TYRES

Check the tyre pressure twice a month.

Front tyre : 26 lbs per sq.in. (1.8 kg/sq.cm).

Rear tyre : 28-31 lbs per sq.in. (2-2.2 kg/sq.cm).

## Running in

Running-in has a vital effect on the satisfactory operation and life of the engine.

Do not push the engine to the limit for the first 300 miles or so. Do not exceed a speed of 25 m.p.h.

Avoid overheating the engine. To do this, assist by pedalling on hills or allow the engine to cool off for a few minutes, while at rest, especially in hot weather.

**Running-in must be continued for about 600 miles.**

From 300 to 600 miles do not exceed average engine speeds that is : 30 m.p.h.



# Starting off

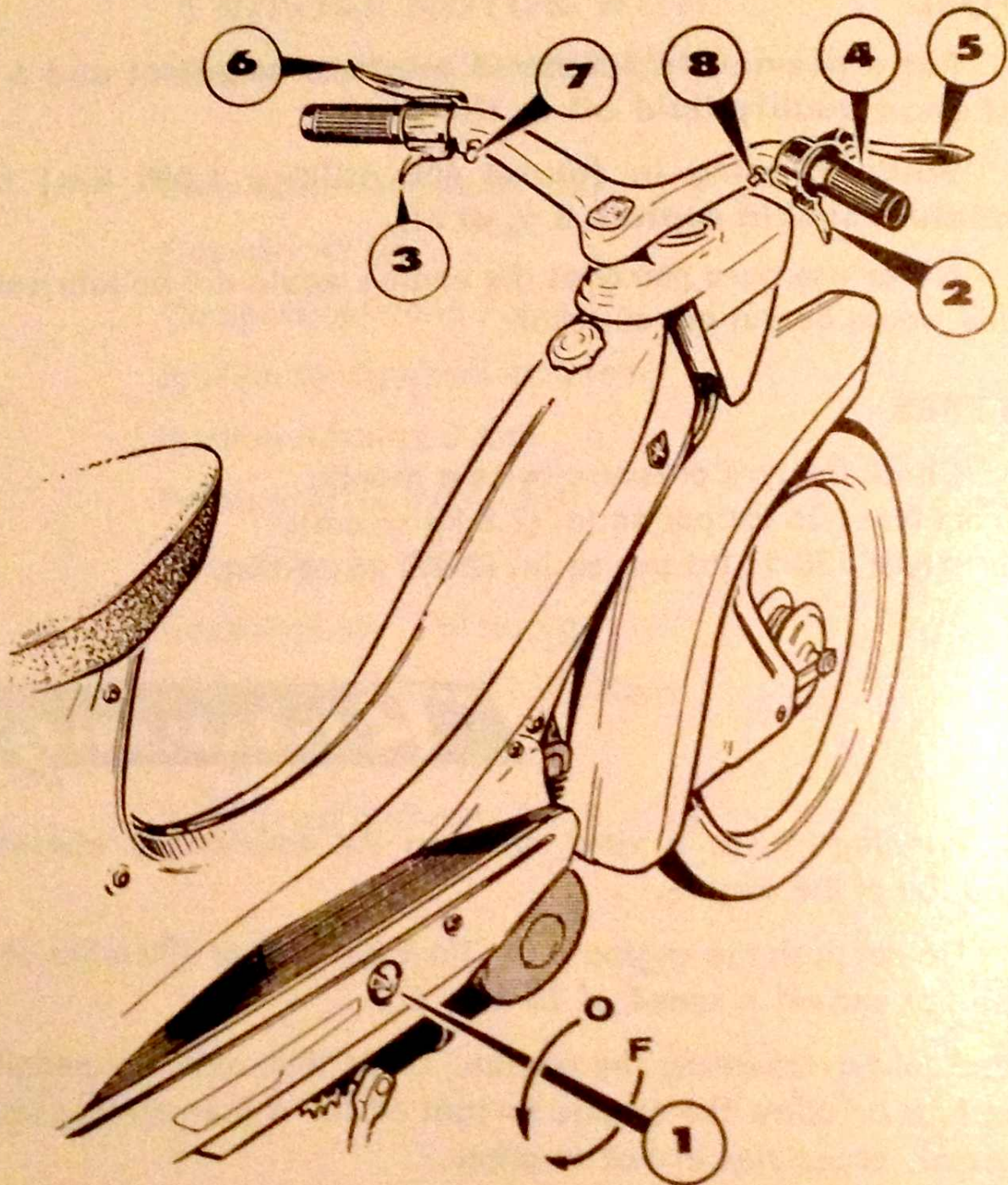

- 1. - Petrol tap.
- 2. - Decompressor.
- 3. - Choke.
- 4. - Throttle.

- 5. - Front brake.
- 6. - Rear brake.
- 7. - Light switch.
- 8. - Horn button.



## STARTING OFF

- I. - Open petrol tap by unscrewing the knob one turn. This is situated at the side of the right-hand foot board (1).
- II. - Fully depress the decompressor trigger (2).
- III. - Spin the motor :
  - either by pedalling,
  - or by placing the machine on its stand and pedalling,
  - or by simply pushing the machine for a few yards at a fast walking pace.During this operation keep the throttle shut or slightly open.
- IV. - As soon as the motor is turning release the decompressor without altering the throttle setting.  
As soon as the motor fires, open the throttle a little and keep motor running with the throttle (4).

### In cold weather

Also depress the choke lever and release a short while after motor is started.

Control with the throttle, but do not try to make the motor run too slowly until it is quite warm.

## *Slowing and stopping*

If the throttle is progressively closed, the machine will slow gently, if braking must be rapid, shut the throttle and apply brakes.

When the machine is stationary, the engine will continue to run thanks to the automatic clutch.

To restart it is only necessary to open the throttle ; on a hill it is worth helping the motor by pedalling.

To stop the motor depress the decompressor lever.



# *the flywheel magneto*

The flywheel magneto is a delicate device and calls for expert knowledge. In the event of failure, we advise our customers first to check the plug and plug lead and only if they are certain the fault lies in the Flywheel Magneto should they touch it and even then with caution.

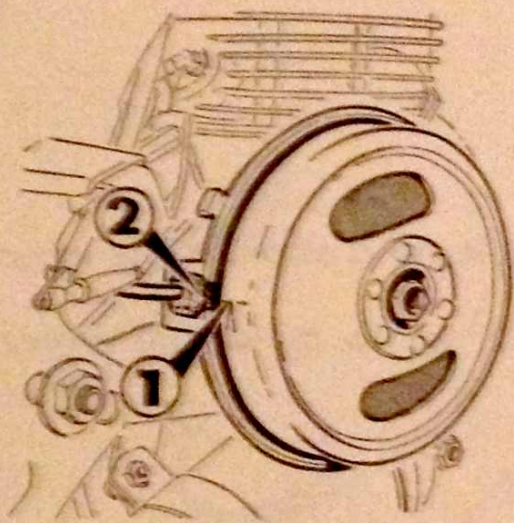

## **CHECKING AND RE-SETTING CONTACT BREAKER**

For a good spark it is necessary that the marks on the flywheel magneto (1) and on the back plate (2) should be in line when the points commence to open.

In order to check this proceed as follows :

- Turn the flywheel magneto in the direction of running until the points commence to open.
- Insert a piece of cigarette paper between the contacts and turn the flywheel magneto back until the paper is just gripped between the contacts.



- Then with the right hand slowly turn the flywheel magneto forward again until the paper (held in the left hand) is just released.
- If the point of opening does not occur when the marks are in line proceed as follows :

Set the 2 marks in line, slacken the fixing screw of the adjustable ignition point, then with a screw-driver turn the point until it is just opening, then re-tighten locking screw.

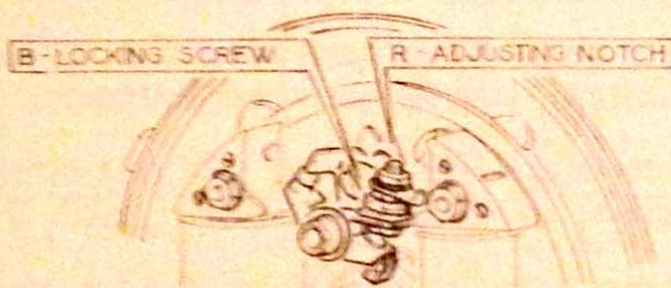

- 1-SLACKEN THE SCREW B
- 2-INSERT A SCREWDRIVER BETWEEN THE NOTCHES R AND ADJUST
- 3-RETIGHTEN THE SCREW B

### VERY IMPORTANT

When the ignition timing is correct, the maximum gap of the ignition points will be about .4 mm (.016 ins.).

However, it may safely be between the limits .012 to .020 ins.

Never adjust to a definite gap, for good running of the flywheel magneto does not depend on the gap, but on the points opening precisely at the moment of greatest change of magnetic flux which occurs when the two marks are in line.



## **FLYWHEEL MAGNETO (cont'd)**

### **CHECKING THE IGNITION TIMING.**

1. - Remove sparking plug.
2. - Insert a graduated ruler into the cylinder through the plughole and find top dead centre by turning the flywheel ; note the position on the ruler.
3. - Slowly turn the flywheel in the opposite direction to running until the piston is 3 mm below top dead centre, make a mark on the ruler corresponding to this position.
4. - Check that with the piston in this position :
  - a) the marks on the flywheel and back plate are in line.
  - b) the contact breaker is on the point of opening.

If these 2 conditions are satisfied, the flywheel magneto is properly timed.

If not, proceed as follows :

Loosen the flywheel from its shaft by unscrewing the lock-nut and withdrawing the flywheel with the correct extractor.

6. - Turn the flywheel in order to align the marks, without altering the position of the piston, as defined in paragraph 3.
7. - Re-tighten the flywheel, being very careful that it does not turn on its shaft at the moment of tightening.
8. - Check, and if necessary, re-adjust contact breaker (see page 6).

## **LUBRICATION**

The grease felt for the contact breaker cam is impregnated with a special grease which will last for 10,000 - 12,000 miles.

At this mileage do not soak in an oil which can cause trouble in the flywheel magneto.

We advise our customers to replace the felt with a new one.



600 miles	Driving Chains Speedometer cable	BP Energol Motor Oil SAE 30
	Control Cables Free Wheel	Vaseline
1,200 miles	Driven Pulley	BP Energrease
3,000 miles	Head races, bottom bracket pedals hubs front and rear, brake cams	L2 Multi- purpose

## WARNING

Do not allow oil or grease to get into brake drums.  
Careful lubrication will prolong the life of your Moped.

## ROUTINE SERVICE :

Every 600 miles.

**Sparking plug** - Remove the plug and clean it with a wire brush. Check the electrode setting which should be about 0.16 ins. (4/10 mm). In the event of the plug being defective, we recommend replacing it with a Marchal 35-36 D.

**Carburettor** - Remove and clean the carburettor with pure petrol.



# *the carburettor*

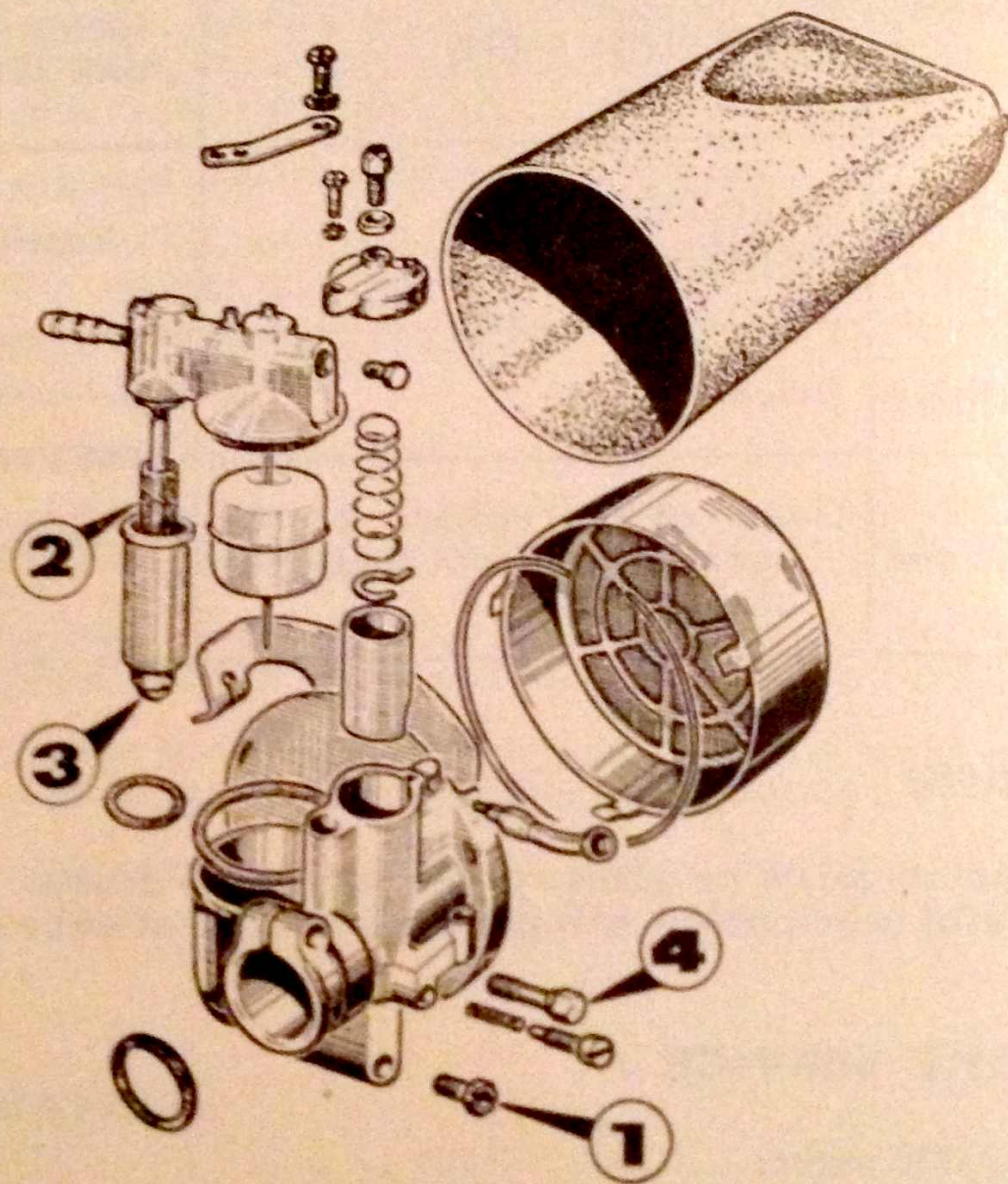

If the main jet is obstructed, also clean the float chamber, the filter bowl and the internal ducts which carry petrol.

**Dismantle and clean the carburettor with pure petrol.**



## **DISMANTLING OF THE CARBURETTOR**

- Remove the footboards.
- Loosen the two engine mounting bolts front and rear.
- Remove driving belt from the driven pulley.
- Loosen Carburettor pinch bolt (4).
- Slide the carburettor backwards and remove from stub.

## **REMOVAL OF MAIN JET**

- The main jet can be removed easily without detaching the carburettor having removed the left footboard.

## **ADJUSTING OF TICK-OVER**

This adjustment is important. It enables the engine to be kept running while the vehicle is at a standstill, so that it can easily start off again merely by opening the throttle. This adjustment is made with one screw on the side of the carburettor and there is a hole in the left footboard through which a screw-driver may be inserted.

1. - Screw the adjusting screw right home.
2. - Start the engine with the machine on its stand.
3. - When the engine is warm, lock the rear wheel with its brake and slowly unscrew the adjuster until the engine is running reliably, as slowly as possible.

Now lower the machine from its stand and mount. The engine should not stall and there should be no difficulty in holding the machine back, although it will show a slight tendency to move off.



# Removal of the rear Wheel

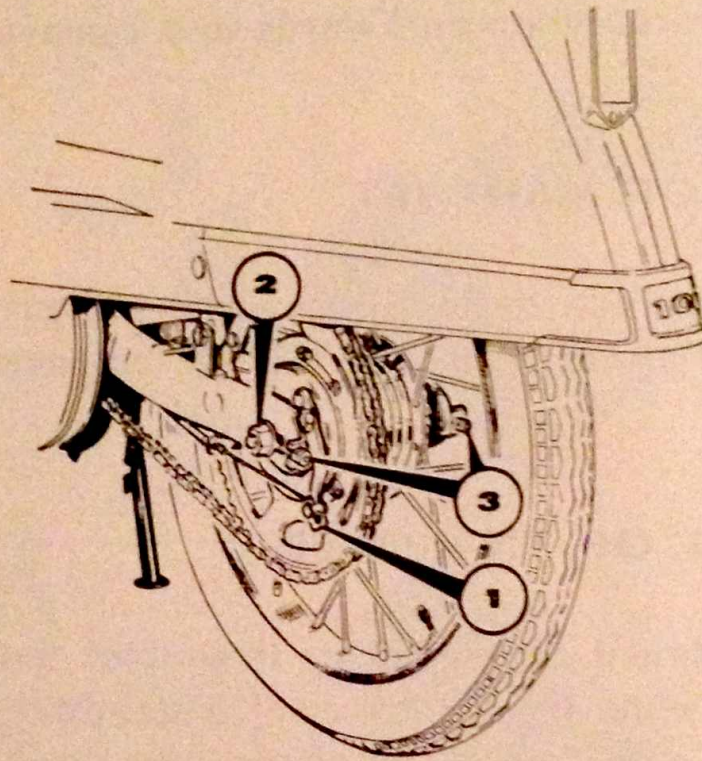

- Disconnect the rear brake cable by pushing its lever forward.
- It is unnecessary to unscrew the solderless nipple.
- Loosen the wheel nuts (2) and withdraw the tensioners (3) without altering their adjustment.
- Push the wheel forward until it may be removed.
- Remove the chains outwards without disconnecting spring links.



# Setting of the driving chain tension

- Loosen the wheel nuts.
- Screw the 2 adjusters the same number of turns until the chain is at its correct tension. **DO NOT OVERTIGHTEN, THE WHEEL MUST TURN FREELY** without a tight spot.
- Tighten the 2 spindle nuts and then the lock nuts of the tensioners. After having re-set the driving chain, check and, if necessary, re-adjust the pedalling chain.

## Disconnection of the motor

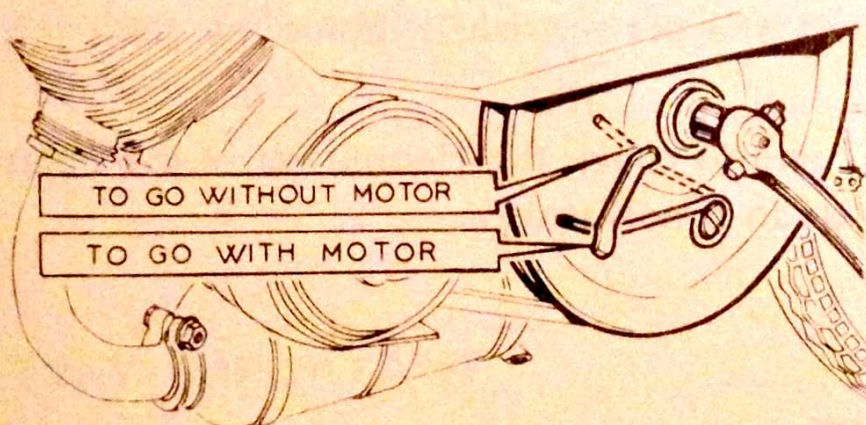

In order to be able to pedal the machine without turning the motor, release the lever on the driven pulley from its position and clip into the position « mise en velo ».

We recommend customers who make frequent or prolonged use of their machine with the engine disconnected, to check the lubrication of the pulley. **THIS SHOULD BE GREASED MORE FREQUENTLY.**



## *Setting of the belt tension*

- Remove the footboards.
- Slacken the 2 engine mounting bolts.
- Re-tension the belt by pivoting the engine forwards with the aid of a lever (maximum free play should be 1/2 in.).
- Tighten the rear bolt first and then front bolt.

## *Removal and cleaning of the silencer*

- Remove the lock nut and the nut which holds the rear end into the silencer.
- Withdraw the rear end to check the cleanliness of the holes in the baffles and clean if necessary.

### **VERY IMPORTANT :**

Do not make extra holes, as the running of the engine may be affected.

Do not force while re-assembling, or you may cause internal damage.



## *Removal of the headlamp*

After having unscrewed the fixing screw, do not attempt to lever off the light unit, but turn in either direction for 1/10 of a turn ; the light unit may now be removed and the bulb holder may be detached.

## *Removal of the front fork*

The front fork need not be removed other than in case of an accident. With normal use the fork requires no servicing whatsoever.

### **VERY IMPORTANT**

On replacement, the pivots of the swinging arm must be tightened with the arm in the central position (distance between spindles of suspension unit approx. 93 mm). These pivots do not require lubrication.



# *Replacement of cylinder head*

## **WARNING :**

Never tighten the cylinder head nuts while the motor is warm. Always re-tighten these nuts little by little and in order, finally tighten firmly.

## *automatic multi-plate clutch*

This clutch operates automatically so that :

- the clutch is disengaged when the machine is stationary permitting the machine to be moved without turning the engine.
- the engine starts by pedalling.
- there is engagement and disengagement of the engine as necessary during normal riding.



Practically indestructible, it requires no maintenance.

Correct adjustment of the slow running of the engine is essential for the proper operation of the clutch. The carburettor is correctly adjusted if with the throttle closed the rear wheel does not turn when the engine is running (with the machine on its stand).

**Note :** If the machine is stopped while running (traffic lights or similar) allow the motor to run as slowly as possible without opening the throttle.

**Lubrication :** Approximately every 1,250 miles the nipple at the end of the shaft should be greased, a little is sufficient (BP Energrelase L2 or similar).

Excess grease can be prejudicial to the running of the clutch. If grease penetrates the clutch drum and soils the linings, the clutch will slip and there will be difficulty in starting.



# *Decarbonisation*

The frequency of decarbonisation depends very much on the quality of the oil used.

With a good quality oil, the engine can cover 6,000 miles without decarbonisation, but with certain oils, decarbonisation may be required more frequently.

## **WARNING**

It is essential that the decompressor valve is quite gas-tight; if it is not, the engine may become overheated and there may be an appreciable power loss.

Check that there is free movement in the decompressor cable. As long as the engine is running properly, do not worry about the carbon deposit.

If the performance of the engine falls off, if it overheats or if it "four strokes" then decarbonisation is necessary. Check the state of the silencer and clean as previously stated. Remove the exhaust pipe and check the condition of the exhaust port. If the exhaust port or the silencer is obstructed, it may only be necessary to clean them.

A complete decarbonisation also involves :

1. - The cleaning of the cylinder head, the top of the piston and eventually the piston ring grooves, in which case new piston rings should be fitted.

2. - Grinding in the decompressor valve and seat. If the valve appears worn do not hesitate to change it.

## **IMPORTANT**

**Never use a scraper or other tool likely to scratch aluminium.**

The replacement of piston rings is difficult, owing to the risk of breakage, and the running of the engine is completely dependent on careful decarbonisation. Accordingly we advise customers to entrust this work to our Dealers.



# **THE ENGINE**



SIMPLE  
FAULT  
FINDING



Crankshaft bearings seals	
30	39.858
31	35.104
32	37.741
33	14.403
34	37.004
35	37.034
36	18.857
37	37.740
38	14.292
39	37.742
40	37.616
41	37.615

Crank-case	
1	40.025
2	37.007 E
3	35.753
4	35.761
5	G. 6-37-12
6	36.608
7	36.609
8	H.U. 6
9	35.752
	35.751

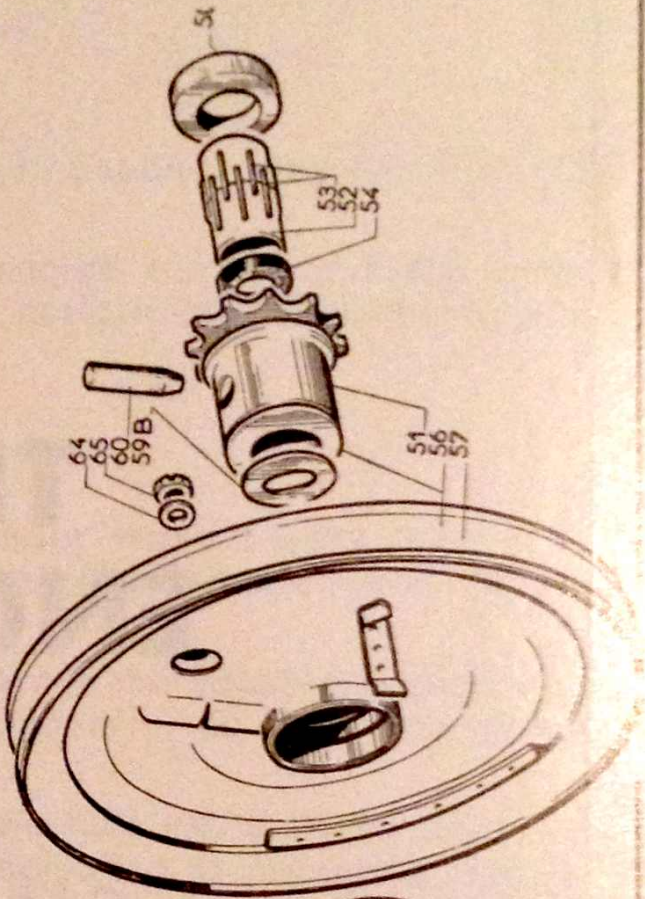
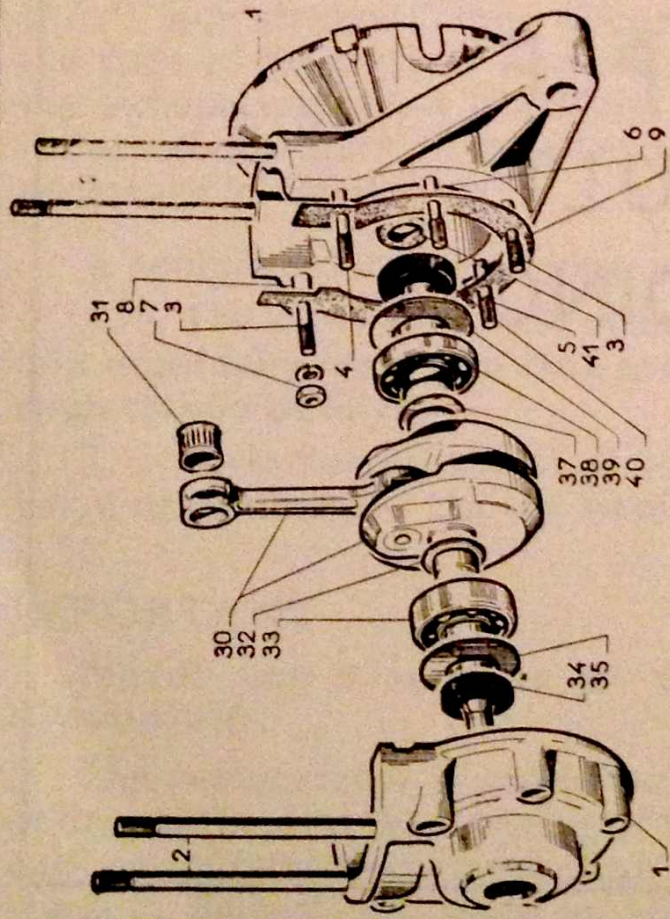

61	37.764
62	37.766
63	37.834
64	L. 7
65	H.B.K. 7
66	V. 2-25
	39.986

Countershaft transmission	
50	38.610
51	37.763
52	47.711
53	37.844
54	36.107
56	38.589
57	37.758
58	38.406
59	37.838
59 B	36.104
60	37.765







# Simple fault finding

## I. - The motor will not run hot or cold :

Symptoms	Defects	Remedy
No spark or poor spark.	<ol style="list-style-type: none"> <li>1 Dirty or short circuit plug, or sparking inside.</li> <li>2 Contact always open, moving point seized on spindle.</li> </ol>	<p>Clean.</p> <ol style="list-style-type: none"> <li>1 or fit fresh sparking plug. Electrode gap .016".</li> <li>2 Dismantle and clean the spindle with fine emery. Reassemble after lubricating with a little graphite oil. Excessive oil could foul the points.</li> </ol>
Petrol failing to arrive regularly at the carburettor and at the main jet.	<ol style="list-style-type: none"> <li>1 Obstructed tap.</li> <li>2 Tap filter clogged.</li> <li>3 Breather hole in filler cap clogged.</li> <li>4 Blocked main jet.</li> </ol>	<p>Check and clean where necessary.</p> <p>Check and clean where necessary.</p> <p>Unblock jet with compressed air or with tyre pump.</p>
Petrol supply satisfactory but cold starting difficult.	<ol style="list-style-type: none"> <li>1 Throttle stop badly set.</li> <li>2 Air leak.</li> </ol>	<p>Check and reset throttle stop. (see page 11).</p> <p>Check the joint of the induction stub to the cylinder and also where the carburettor is joined to the induction stub.</p>
Petrol floods from carburettor and motor will not start.	<ol style="list-style-type: none"> <li>1 Float needle fails to seal petrol.</li> </ol>	<p>Check that the needle does seal and if not clean.</p>



## 2. - The Motor starts satisfactorily but runs irregularly.

Symptoms	Defects	Remedy
Difficulty to start the engine when lights are on. When running the motor commences to misfire when the lights are turned on.	<ol style="list-style-type: none"><li>1 Ignition points do not open sufficiently.</li><li>2 Burnt contact points or points out of alignment.</li><li>3 Worn plug with dirtied electrodes.</li></ol>	<ol style="list-style-type: none"><li>1 Reset points. (see page 7).</li><li>2 File away the cam follower of the points and reset the contacts, or better still, replace contact set.</li><li>3 Clean or change the plug, if necessary.</li></ol>



ASSEMBLY INSTRUCTIONS  
FOR  
PEUGEOT MOTOR BIKE

MODEL 104

1. Unpack and check packing material to be sure that no parts are being discarded.
2. Check to see if left brake lever on handlebar operates rear brake cable. If not, switch handles before mounting handlebars. Left lever will operate rear brake. Right lever will operate front brake.
3. Mount handlebars. Push down as far as possible. Bolt through cowling in head lamp. Discard spacer bolt. Connect left brake cable to the rear brake arm at the drum. Connect right brake cable to the front brake arm at the drum. Spin wheels by hand to be sure brakes are not too tight. Adjust brake cables to secure proper braking action.
4. Left hand trigger will be for the choke. Attach the choke cable to arm on top of carburetor.
5. Right hand trigger will be for the decompressor. Attach the decompressor cable to the decompressor valve at top of cylinder head. Attach the right hand twist grip throttle cable at top of carburetor.
6. Attach plastic gas line to valve under right hand step board.
7. Mount leg shields, right side first. Follow this procedure:
  - a) Using bolts and nuts from plastic bag, insert bolts through holes in frame bracket to which horn is attached. Threads down.
  - b) Remove front locking bolt from step board. Loosen other bolts holding step board.
  - c) Slide leg shields into place, lining up holes in lower portion with holes at front of step board.
  - d) Be sure leg shield brackets are in position so that the two bolts in the frame bracket at horn will pass through frame bracket and both leg shield brackets.
  - e) Drive long bolt at upper end of Right leg shield through the channels of both leg shields and fasten with the small nut.
  - f) Tighten step board bolts.
8. Attach pedals, right hand and left hand. Inflate tires to: Front, 26 lbs.; Rear, 30 lbs.
9. CAUTION: Mix one-half (1/2) pint of good quality SAE motor oil #30 with one (1) gallon regular gasoline.
10. Fill gas tank with this gasoline and oil mixture. Open gasoline valve and start engine. Your motor bike is now ready to operate.

CONTINENTAL CYCLES CORPORATION

Harper Woods, Mich. 48236